

IREEE_Indar_2012.pdf

by Turnitin Indonesia .

Submission date: 16-Apr-2022 01:30AM (UTC-0400)

Submission ID: 1811915150

File name: IREEE_Indar_2012.pdf (1.03M)

Word count: 3316

Character count: 17235

Steady State Stability Assessment Using Extreme Learning Machine Based on Modal Analysis

Indar Chaerah Gunadin^{1,2}, Adi Soeprijanto¹, Ontoseno Penangsang¹

Abstract – The growth of electricity market led to increase utilization and higher loading of the electric transmission grids worldwide. This situation made power system operate close to steady-state stability limit (SSSL). It could trigger voltage instability or voltage collapse phenomenon. An assessment approach on steady state stability analysis was provided using Extreme Learning Machine taking the Modal Analysis as an assessment index. The nonlinear problem between voltage, power flow and participation factor in power system could be solved by Extreme Learning Machine. The method was tested on the IEEE 14 bus and Java-Bali system. The simulation results showed that the proposed method could accurately predict the weakest bus in power system. Copyright © 2012 Praise Worthy Prize S.r.l. - All rights reserved.

Keywords: Voltage Collapse, Steady State Stability, Extreme Learning Machine, Modal Analysis

Nomenclature

ΔP	Active power
ΔQ	Reactive power mismatch
J	Jacobian matrix
J_R	Jacobian reduction matrix
ΔV	Voltage magnitude
$\Delta \theta$	Angle correction
Φ	Right eigenvector matrix of J_R
Γ	Left eigenvector matrix of J_R
Λ	Triagonal eigenvalue matrix of J_R
P_{ki}	Participation of the k^{th} bus in i^{th} mode

I. Introduction

Nowadays, in electric power system, load growth is not accompanied by the rapid development of transmission networks and generation capacity. This condition will cause the electric power system to operate at conditions that are particularly vulnerable to the phenomenon of a voltage instability or a voltage collapse. Nowadays, the voltage collapse has become a very important issue in the operation of electric power systems [1]-[3].

There are many researchers who have evaluated the technique to predict a voltage collapse in power systems. Morison and Kundur provide a method named Modal Analysis. This method is performed by calculating the eigen value and eigenvector of the Jacobian reduction matrix of system power. Power system stability condition can be determined by observing the results of these eigen values. If all the eigen values are positive, the system is considered to be in a stable condition. On the other hand, if eigen values are negative, the system is considered to be in an unstable voltage.

Furthermore, by applying methods of bus participation factor, the weakest bus or node can be determined - which is the greatest contributing factor for a system to reach a voltage collapse situation-[2].

This paper proposes an artificial intelligent namely a Extreme Learning Machine (ELM) approach for an assessment of steady state stability. The nonlinear characteristic between power flow and voltages on load bus with given load increases mode. However, as the operating conditions of a power system continuously change it is difficult to calculate the bus participation factor for each load bus directly by the mathematical analysis online. As a result, this paper presents ELM method to estimate the participation factor sequentially to assess the system voltage stability rapidly and timely.

II. The Modal Analysis

The modal analysis or eigen value analysis can be used effectively as a powerful analytical tool to verify both proximity and mechanism of a voltage instability. It involves the calculation of a small number of eigen values and related eigenvectors of a reduced Jacobian matrix. However, by using the reduced Jacobian matrix, the focus is on the voltage and the reactive power characteristics. The weak modes (weak buses) of the system can be identified from the system reactive power variation sensitivity to incremental change in bus voltage magnitude. The stability margin or distance to voltage collapse can be estimated by generating the Q-V curves for that particular bus. Load characteristics have been found to have significant effect on power system stability. A simplified voltage dependent real and reactive power load model is used to figure out that effect. Induction machine is one of the important power

system loads. It influences the system voltage stability especially when large amount of such load is installed in the system[3].

Equation (1) represents the power flow equation in power system at such as an operating system:

$$\begin{bmatrix} \Delta P \\ \Delta Q \end{bmatrix} = \begin{bmatrix} J_{11} & J_{12} \\ J_{21} & J_{22} \end{bmatrix} \begin{bmatrix} \Delta \theta \\ \Delta V \end{bmatrix} \quad (1)$$

with assumption:

$$\begin{aligned} \Delta P = 0 &= J_{11} \Delta \theta + J_{12} \Delta V \\ \Delta \theta &= -J_{11}^{-1} J_{12} \Delta V \end{aligned} \quad (2)$$

and:

$$\Delta Q = J_{21} \Delta \theta + J_{22} \Delta V \quad (3)$$

Substituting equation (2) in equation (3):

$$\Delta Q = J_R \Delta V \quad (4)$$

where :

$$J_R = \begin{bmatrix} J_{22} - J_{21} J_{11}^{-1} J_{12} \end{bmatrix} \quad (5)$$

The matrix J_R represents the linearized relationship between the incremental changes in bus voltage (ΔV) and bus reactive power injection (ΔQ).

Voltage instability can be detected by identifying modes of the eigenvalues matrix J_R . Eigenvalue analysis of J_R results in the following:

$$J_R = \Phi \Lambda \Gamma \quad (6)$$

By changing the J_R to J_R^{-1} :

$$J_R^{-1} = \Phi \Lambda^{-1} \Gamma$$

If Φ_i and Γ_i represent the right- and left- hand eigenvectors respectively for the eigenvalue λ_i of the matrix J_R , the participation factor measuring the participation of the k^{th} bus in i^{th} mode is defined as:

$$P_{ki} = \Phi_{ki} \Gamma_{ik} \quad (7)$$

So the eigenvalues of importance are the critical eigenvalues of the reduced Jacobian matrix J_R . Thus, the smallest eigenvalues of J_R are taken to be the least stable modes of the system. The rest of the eigenvalues are neglected because they are considered to be strong enough modes.

Once the minimum eigenvalues and the corresponding left and right eigenvectors have been calculated, the

participation factor can be used to identify the weakest node or bus in the system[2]-[3].

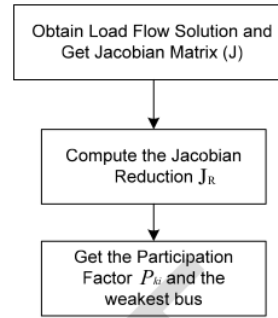

Fig. 1. Algorithm of Modal Analysis

III. Extreme Learning Machine

Conventional methods such as back-propagation (BP) and the method of Levenberg-Marquardt (LM) have been used extensively in training neural networks although this algorithm is relatively slow in learning. A new learning method for single-hidden-layer feed forward neural-networks (SLFNs) is the so-called extreme learning machine (ELM). In ELM, the input weights and hidden biases are randomly chosen. The output weights obtained using the Moore-Penrose (MP) generalize inverse. ELM has the capability in terms of speed and it is easier than traditional methods of gradient-based learning algorithms [8]-[9].

In ELM, the input weights and hidden biases are generated randomly. Furthermore, the nonlinear system has been transformed into a linear system:

$$H\beta = T$$

Whereas named in Huang et al. [15], $H = \{h_{ij}\}$, $i=1, \dots, N$ and $j=1, \dots, K$ is hidden-layer output matrix, $\beta = [\beta_1, \beta_2, \dots, \beta_K]^T$ is matrix of output weights and

$T = [t_1, t_2, \dots, t_N]^T$ is matrix of targets. In this paper, ELM is utilized to map the highly non-linear relationship between network voltage profile, power generation of power system and the corresponding bus participation factor of power system. First, the simulation starts with running the power flow program for IEEE 14 bus and Java-Bali system. Then, by using Modal Analysis, the weakest bus of each cases will be obtained. The data from modal analysis will be training in ELM.

IV. Application of Extreme Learning Machine

Bus participation factor values were obtained from the Modal Analysis method and then trained at Extreme Learning Machine. Data input was the generator bus

voltage, active power and reactive generator, four of the largest values of participation factor, the change of power at the load bus.

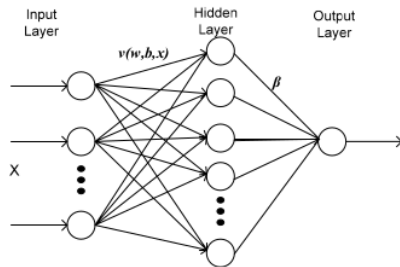

Fig. 2. Structure of an SLF-NN

In this simulation, the input data used was as many as 150 data in which 30 data were used as testing data. Algorithm of this study can be seen in Fig. 4.

Application of Modal Analysis method for IEEE-14 bus and Java-Bali system would obtain the bus participation factor values as shown in Fig. 5 and Fig. 6.

In this simulation, the relationship between changes in bus loads to the bus participation factor would be obtained.

The load on bus number 4 has been changed, so for any changes in this value, the new participation factor for all load buses would be obtained.

The value of participation factor was taken as the input data. This data were limited to 4 ELM greatest value of participation factor, namely: Bus 9, Bus 10, Bus 11 and Bus 14.

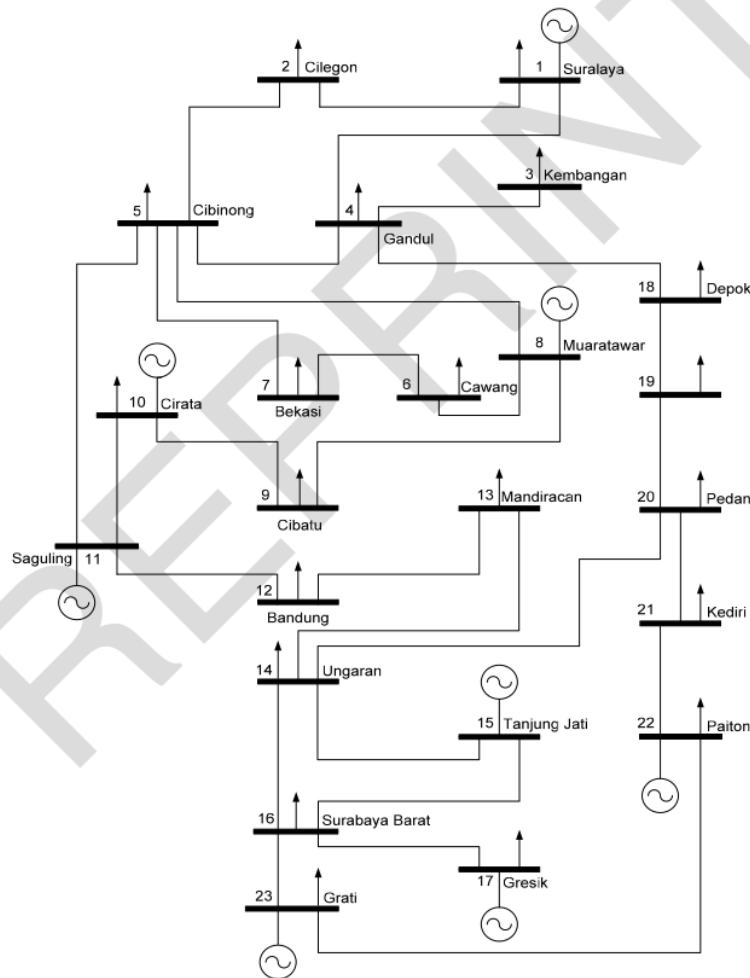

Fig. 3. Single Line Diagram of 500 kV Java-Bali Power System

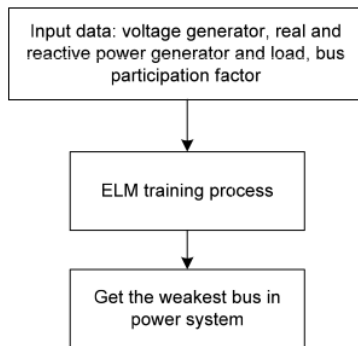

Fig. 4. Simulation process of ELM Method

Active and reactive power data for generator, the voltage at any bus generator, the voltage at the load bus, and load change at bus 4 were used as input data and the fourth largest participation values were used as data output for the ELM method, as shown in Table I.

Activation function in this simulation was the sigmoid method. After the simulation, the results obtained were:

Average Testing Accuracy = 2.6383e-004
 Average Training Accuracy = 3.1689e-024

Average Training Time = 0.1477
 Average Testing Time = 0.0233

The process of training indicated that: time was short and error was small. So we could conclude that the ELM could be used to estimate the modal analysis and improve the stability of steady state conditions.

For Java-Bali case, the load changes were given in bus 12. With the simulation steps as in IEEE-14 bus system, participation factor values obtained with the max error was 0.0764:

Average Testing Accuracy = 0.0019

Average Training Time = 0.0324

Average Testing Time = 0.0030

Testing Accuracy = 7.0417e-004

Training Time = 0.0313

Training Accuracy = 1.1445e-016

After going through the training process, ELM was tested using test data. This data were not included in the training process. In the picture, look 4 the ratio of the highest bus participation factor in the IEEE-14 bus system.

The weakest bus is bus 14, followed by bus 10, bus 9 and bus 11 respectively. This value of participation factor will change the value of any change in the load bus.

TABLE I
 SAMPLE OF DATA INPUT FOR EXTREME LEARNING MACHINE FOR IEEE 14 BUS' SYSTEM

PI	QI	V1	...	V2	V3	V6	V8	PL4	QL4	PF9	PF10	PF11	PF14
Real Power G1	Reactive Power G1	Bus Voltage	...	Bus Voltage	Bus Voltage	Bus Voltage	Bus Voltage	Real Power Bus Load	Reactive Power Bus Load	Part. factor bus 9	Part. factor bus 10	Part. Factor bus 11	Part. factor bus 14
1.517	0.308	1.06	...	1.04	1.01	1.07	1.08	0.967	0.3383	0.1912	0.2319	0.1095	0.327
1.528	0.306	1.06	...	1.04	1.01	1.07	1.08	0.977	0.338	0.1912	0.2319	0.1095	0.327
1.551	0.314	1.06	...	1.04	1.01	1.07	1.08	0.997	0.438	0.1914	0.232	0.1094	0.3266
1.564	0.324	1.06	...	1.04	1.01	1.07	1.08	1.007	0.538	0.1914	0.2321	0.1094	0.3262
1.679	0.331	1.06	...	1.04	1.01	1.07	1.08	1.107	0.738	0.1921	0.2323	0.109	0.3254
1.794	0.326	1.06	...	1.04	1.01	1.07	1.08	1.207	0.8383	0.1924	0.2325	0.1089	0.3249
1.91	0.322	1.06	...	1.04	1.01	1.07	1.08	1.307	0.9383	0.1927	0.2326	0.1087	0.3243
2.027	0.319	1.06	...	1.04	1.01	1.07	1.08	1.407	1.038	0.193	0.2327	0.1085	0.3237
2.145	0.317	1.06	...	1.04	1.01	1.07	1.08	1.507	1.138	0.1933	0.2328	0.1083	0.3231
2.265	0.315	1.06	...	1.04	1.01	1.07	1.08	1.607	1.238	0.1936	0.233	0.1081	0.3225

TABLE II
 SAMPLE OF DATA INPUT FOR EXTREME LEARNING MACHINE FOR JAVA-BALI' SYSTEM

PI	QI	V1	...	PL12	QL12	PF14	PF19	PF20	PF21
Real Power G1	Reactive Power G1	Bus Voltage G1	...	Real Power Bus Load 12	Reactive Power Bus Load 12	Part. factor bus 14	Part. factor bus 19	Part. Factor bus 20	Part. factor bus 21
3.323	0.957	1.02	...	0.59	0.351	0.0867	0.3688	0.281	0.1657
3.426	0.963	1.02	...	0.69	0.451	0.0868	0.3686	0.281	0.1656
3.529	0.97	1.02	...	0.79	0.551	0.0869	0.3683	0.281	0.1655
3.633	0.978	1.02	...	0.89	0.651	0.087	0.3681	0.2809	0.1654
3.737	0.986	1.02	...	0.99	0.751	0.0871	0.3679	0.2809	0.1653
3.84	0.996	1.02	...	1.09	0.851	0.0873	0.3676	0.2808	0.1652
3.945	1.006	1.02	...	1.19	0.951	0.0874	0.3674	0.2808	0.1651
4.049	1.017	1.02	...	1.29	1.051	0.0875	0.3671	0.2807	0.165
4.154	1.029	1.02	...	1.39	1.151	0.0876	0.3669	0.2807	0.1648
4.259	1.042	1.02	...	1.49	1.251	0.0877	0.3667	0.2806	0.1647
4.364	1.055	1.02	...	1.59	1.351	0.0878	0.3665	0.2805	0.1646
4.47	1.07	1.02	...	1.69	1.451	0.0879	0.3662	0.2804	0.1644
4.576	1.085	1.02	...	1.79	1.551	0.088	0.366	0.2803	0.1643

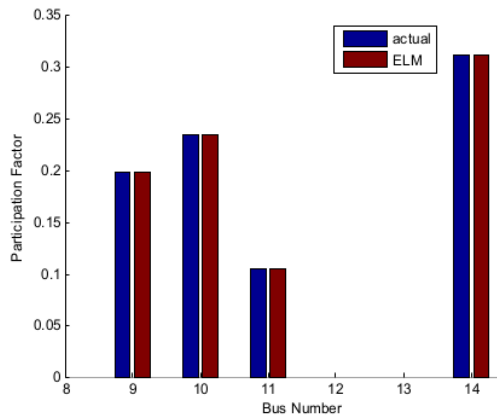

Fig. 5. Comparison of Modal Analysis and ELM Result for IEEE 14 Bus

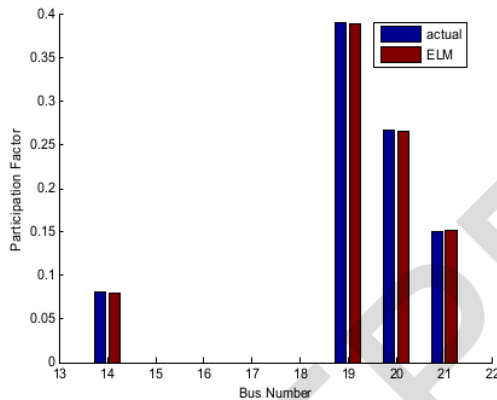

Fig. 6. Comparison of Modal Analysis and ELM Result for Java-Bali

TABLE III
THE COMPARISON OF DATA TESTING AND ELM RESULTS
FOR IEEE 14 BUS SYSTEM

Testing Data PF	Learning PF	Errors
0.1049	0.105	0.003
0.1045	0.1048	0.0101
0.1039	0.1046	0.0244
0.1034	0.1043	0.0495
0.3114	0.3119	0.0007
0.3098	0.3115	0.0025
0.3079	0.3117	0.0052
0.3058	0.3127	0.0105

TABLE IV
THE COMPARISON OF DATA TESTING AND ELM RESULTS
FOR JAVA-BALI SYSTEM

Testing Data PF	Learning PF	Errors
0.361	0.3621	0.0006
0.3608	0.3651	0.001
0.3605	0.3771	0.0102
0.3603	0.3878	0.0049
0.3601	0.4471	0.0518
0.2764	0.2749	0.0031
0.2761	0.2717	0.0118
0.2758	0.2619	0.0461
0.2755	0.2433	0.0764

In the Java-Bali system, buses having the largest participation for instability is bus 19 in a row followed by the bus 20, bus 21 and bus 14. Bus 12 (Bandung Selatan) was used as bus load changes. Any change in the load on this bus will affect the change in the value of power generation, the generator terminal voltage, load bus voltage and the bus participation factor. All of these change the value in teaching the ELM.

V. Conclusion

In this paper, the estimated result obtained from ELM method showed that this approach was able to predict the voltage stability condition in power system. The result showed that Modal Analysis and ELM had overall error in output values was less 0.07 which would be acceptable and it meant that the ELM method had strong potential to be a useful tool for a voltage stability assessment and suitable for on line steady state stability assessment of power system.

References

- [1] Savu C.Savulescu. Real-Time Stability Assessment in Modern Power System Control Center. *IEEE Press. Wiley*, 2009
- [2] Gao, B., Kundur, P., Morisson, G.K. "Voltage Stability Evaluation Using Modal Analysis". *IEEE Transactions on Power Systems*, vol. 7, no. 4, pp. 1423-1543, (November 1992).
- [3] Kundur, P., "Power System Stability and Control", *Mc-Graw Hill, New-York*, 1994, pp 960-971.
- [4] Ching-Yin Lee, ShaoHong Tsai, Yuan-Kang Wu. A New Approach to The Assessment of Steady-State Voltage Stability Margin Using P-Q-V Curve, *Electrical Power and Energy System*, 2010
- [5] Yang Wang, Wenyuan Li, Jiping Lu. A New Node Voltage Stability Index Based on Local Phasors, *Electrical Power and Energy System*; 79; 265-271, 2009
- [6] M.Moghavveni, M.O. Faruque, Power System Security and Voltage Collapse: A Line Outage Based Indicator for Prediction, *Electrical Power and Energy System*, 1999; 21; pp 455-461
- [7] M.H. Haque. A Fast Method for Determining The Voltage Stability Limit of a Power System. *Electrical Power and Energy System*, 1995; 32; pp.35-43
- [8] B.Jeyasurya, Extreme Learning Machine for Power System Steady-State Voltage Instability Evaluation. *Electrical Power and Energy System*, 2010, 29, pp.85-90
- [9] ELM Larsson, Alain Germond, Boming Zhang. Application of Neural Networks to the Identification of Steady State Equivalents of External Power Systems, *International Conference On Power System Technology*, Chongqing, October 2006
- [10] C.W. Taylor, D. C. Erickson, K. E. Martin, and V. Venkatasubramanian, "WACS-wide-area stability and voltage control system: R&D and online demonstration," *Proceedings of the IEEE*, May 2005, Vol. 93, No. 5, pp. 892 - 906,
- [11] G. Benmouyal, E.O. Schweitzer, and A. Guzman, "Synchronized Phasor Measurement in Protective Relays for Protection, Control, and Analysis of Electric Power Systems," *Western Protection Day Conference*, 29 Annual, October 2002
- [12] IEEE/CIGRE Joint Task Force on Stability Terms and Definitions, Definition and Classification of Power System Stability, *IEEE Transactions on Power Systems*, May 2004 Vol. 6, No. 2, pp.1387-1401.
- [13] Y.Xu, Z.Y.Dong, K.Meng, R.Zhang, K.P.Wong, Real-time Transient Stability Assessment Model Using Extreme Learning Machine, *IET Gener. Transm. Distrib.*, 2011, Vol.5, Iss.3, pp.314-322

- [14] Huang, G.-B., Zhu, Q.-Y., Siew, C.-K.: 'Extreme learning machine: theory and applications', *Neurocomputing*, 2006, 70, pp. 489-501
- [15] Huang, G.-B., Xiaoqian Ding, Hongming Zhou, Optimization Method Based Extreme Learning Machine for Classification, *Neurocomputing*, 2010, 74, pp.155-163
- [16] Qin-Yu Zhu, A.K. Qin, P.N. Suganthan, Guang-Bin Huang Evolutionary extreme learning machine, *Pattern Recognition Society*, 2005, 38, pp. 1759 – 1763
- [17] M. Hosseini, Voltage Stability Analysis and Contingency Ranking in Power Systems Using Neural Network, *International Review of Electrical Engineering (IREE)*, October 2010 (part A), Vol. 3. n. 5, pp. 876-881

Authors' information

¹Institut Teknologi Sepuluh Nopember.

²Universitas Hasanuddin.



Indar Chaerah Gunadin was born in Indonesia in 1973. He is a lecturer of Hasanuddin University. He received the M.S degree in electrical engineering from Sepuluh Nopember Institute of Technology (ITS), Indonesia, in 2006. He is currently a Doctoral Candidate of Department of Electrical Engineering ITS. His research interest include power system stability, FACTS Device, Artificial Intelligent and control.



Adi Soeprijanto was born in Indonesia in 1964. He received the Ph.D degree in electrical engineering from Hiroshima University, Japan, in 2001. He is currently a Professor of Department of Electrical Engineering, Sepuluh Nopember Institute of Technology (ITS). His research interest includes power system dynamic and control applications.



Ontoseno Penangsang was born in Indonesia in 1949. He received the Ph.D degree in electrical engineering from University of Wisconsin, USA, in 1983. He is currently a Professor of Department of Electrical Engineering, Sepuluh Nopember Institute of Technology (ITS). His research interest include power system analysis and power quality.

International Review of Electrical Engineering (IREE)

(continued from outside front cover)

- 12
Optimal Reactive Supervision of Grid Connected PV Systems with Batteries in Real Conditions 4607
by Y. Riffonneau, S. Bacha, F. Barruel, Y. Baghzouz, E. Zamaï
- Design and Experimental Implementation of Energy Subsystem of Photovoltaic Radio Station** 4616
by Y. Sangsefidi, S. Ziainejad, A. Shoulaie
- 8
Optimum Capacitor Placement and Sizing for Distribution System Based on an Improved Voltage Stability Index 4622
by M. M. Aman, G. B. Jasmon, A. H. A. Bakar, H. Mokhlis
- 3
Interruptible Load Included Reserve Procurement Method with Wind Power Integration 4631
by Yun-Li Zhao, Quan-Sheng Zhu, Juan-Juan Wang, Wei-Dong Li
- 3
Study on the Morphology and Propagation of Electrical Treeing by Partial Discharge Patterns in XLPE Power Cables 4639
by Chao Tang, Jiao Li, Ruijin Liao, Tianchun Zhou

Abstracting and Indexing Information:

Science Citation Index Expanded™ (SciSearch) - ISI Thomson
*Journal Citation Reports/Science Edition - ISI Thomson: **Impact Factor 1.364***
Academic Search Complete - EBSCO Information Services
Elsevier Bibliographic Database SCOPUS
Cambridge Scientific Abstracts - CSA/CIG
*Index Copernicus (Journal Master List): **Impact Factor 13.31***

Autorizzazione del Tribunale di Napoli n. 31 del 5/04/2006

ORIGINALITY REPORT

18%

SIMILARITY INDEX

13%

INTERNET SOURCES

13%

PUBLICATIONS

10%

STUDENT PAPERS

PRIMARY SOURCES

1

currentelectricinc.com

Internet Source

2%

2

Xiaoqing Han, Zhijing Zheng, Nannan Tian, Yuanyuan Hou. "Voltage Stability Assessment Based on BP Neural Network", 2009 Asia-Pacific Power and Energy Engineering Conference, 2009

Publication

2%

3

connection.ebscohost.com

Internet Source

1%

4

Submitted to University of Malaya

Student Paper

1%

5

Submitted to Auston Institute of Management and Technology

Student Paper

1%

6

dr.ntu.edu.sg

Internet Source

1%

7

I C Gunadin, Z Muslimin, A M Ilyas, A Siswanto. "Control Design of Automatic Voltage Regulator to Improve the Voltage

1%

Stability at Sengkang Power Plant, South Sulawesi Indonesia", IOP Conference Series: Materials Science and Engineering, 2020

Publication

8	core.ac.uk Internet Source	1 %
9	Hany E. Z. Farag, Ehab F. El-Saadany. "Optimum Shunt Capacitor Placement in Multimicrogrid Systems With Consideration of Islanded Mode of Operation", IEEE Transactions on Sustainable Energy, 2015 Publication	1 %
10	Saumendra Sarangi, Ashok Kumar Pradhan. "Adaptive Direct Underreaching Transfer Trip Protection Scheme for the Three-Terminal Line", IEEE Transactions on Power Delivery, 2015 Publication	1 %
11	aip.scitation.org Internet Source	1 %
12	hal.archives-ouvertes.fr Internet Source	1 %
13	Submitted to Karunya University Student Paper	1 %
14	Submitted to University of Babylon Student Paper	1 %

15 I C Gunadin, Z Muslimin, A M Ilyas, A Siswanto. "Comparison of Voltage Stability Index Before and After Wind Turbine Penetrated to Sulsebar Interconnection Power System Using Modal Analysis Method", IOP Conference Series: Materials Science and Engineering, 2020 1 %
Publication

16 Indar Chaerah Gunadin, Zaenab Muslimin, Agus Siswanto. "Transient stability improvement using allocation power generation methods based on moment inertia", 2017 International Conference on Electrical Engineering and Informatics (ICELTICs), 2017 1 %
Publication

17 raiith.iith.ac.in 1 %
Internet Source

18 Submitted to A'Sharqiyah University, Oman 1 %
Student Paper

19 Submitted to Tikrit University 1 %
Student Paper

Exclude quotes Off

Exclude matches Off

Exclude bibliography Off